

LF series

- 高頻率，低阻抗，高可靠性。
- 105°C負荷壽命達3000到5000小時。
- 符合RoHS要求。
- High frequency , low impedance , high reliability .
- Load life 3000 hours to 5000hours at 105°C
- RoHS Compliant .



●SPECIFICATIONS

項目Item	特性Performance Characteristics		
適用溫度範圍 Operating Temperature Range	-40to+105°C	-25to+105°C	
工作電壓範圍 Rated Voltage Range	6.3to100VDC	160to450VDC	
靜電容量誤差 Capacitance Range	0.1to4700 μF	0.47to220 μF	
電容量允差 Capacitance Tolerance	±20% (100Hz or 120Hz , +20°C)		
洩漏電流 Leakage Current (+20°C , 最大max)	I ≤ 0.01CV或5 (μA) 額定工作電壓充電1分鐘後讀數, 取大者 I ≤ 0.01CV or 5 (μA) After 1minutes, whichever is greater measured with rated working voltage applied	I ≤ 0.02CV+10 (μA) 額定工作電壓充電1分鐘後讀數, 取大者 I ≤ 0.02CV+10 (μA) After 1minutes, whichever is greater measured with rated working voltage applied	
散逸因素 (tan δ) Dissipation Factor (tg δ)	工作電壓Working Voltage (VDC)	6.3 10 16 25 35 50 63 100 160 200 250 400 450	
	D.F.(%)最大	20 18 16 14 12 10 10 10 14 14 14 15 17	
容量>1000 μF時 , 每增加1000 μF D.F值增加2% (100Hz or 120Hz , +20°C) For capacitance >1000 μF, Add 2% per another 1000 μF (100Hz or 120Hz , +20°C)			
低溫特性 Low Temperature Characteristics (120Hz)	阻抗比, 最大Impedance ratio , max		
	工作電壓 Working Voltage (VDC)	6.3 10 16 25 35 50 63 100 160 200 250 350 400 450	
	Z - 25°C / Z+20 °C	4 3 2 2 2 2 2 2 2 2 3 5 6 15	
Z - 40°C / Z+20 °C	8 6 4 3 3 3 3 3 - - - - -		
容量>1000 μF時 , 每增加1000 μF , Z - 25°C / Z+20 °C值增加0.5%, Z - 40°C / Z+20 °C值增加1% For capacitance >1000 μF , and 0.5% per another 1000 μF for Z-25°C/Z+20°C, add 1% per another 1000 μF for Z-40°C/Z+20°C			
負荷壽命Load Life	試驗條件	Test conditions	
	持續時間:8000~12000小時	Duration time: 2000hours	
	環境溫度:+105°C	Ambient temperature: +105°C	
	施加電壓:額定工作電壓(VDC)	Applied voltage: Rated Working Voltage(DVC)	
	施加額定紋波電流	Applied voltage: Rated Working Voltage(mA)	
	試驗後要求:室溫下恢復16小時,+20°C測試	After test requirements: Resumde 16 hours at normal temperature	
	電容量變化:≤20%規定值	Capacitance change:≤20% of the initial measured value	
	損耗角正切值:≤200%初始值	Dissipation Factor:≤200% of the initial specified value	
漏電流:≤規定值	Leakage Current:≤The initial specified value		
放置壽命Shelf Life	試驗條件	Test conditions	
	持續時間: 500小時	Duration time: 500hours	
	環境溫度:+105°C	Ambient temperature:+105°C	
	施加電壓:無	Applied voltage: None	
	試驗後要求:室溫下恢復16小時,+20°C測試	After test requirements: Resumed 16 hours at normal temperature	
	電容量變化:≤20%規定值	Capacitance change:≤20% of the initial measured value	
	損耗角正切值:≤200%初始值	Dissipation Factor:≤200% of the initial specified value	
試驗條件漏電流:≤200%規定值	Leakage Current:≤200% of the initial specified value		

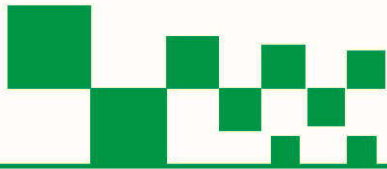

試驗條件紋波電流頻率調整系數

Multiplier for ripple current vs. frequency

容量 (μF) / Hz		120	1K	10K	50K~100K
系數	<220	0.40	0.75	0.90	1.00
	220 ≤ cap < 680	0.50	0.85	0.94	1.00
	680 ≤ cap < 2200	0.60	0.87	0.95	1.00
	2200 ≤ cap < 4700	0.75	0.90	0.95	1.00
	Cap ≥ 4700	0.85	0.95	0.98	1.00

紋波電流溫度調整系數

Multiplier for ripple current vs. temperature

溫度°C	45	60	70	85	105
系數	2.10	1.90	1.40	1.25	1.00

●DIMENSIONS(mm)

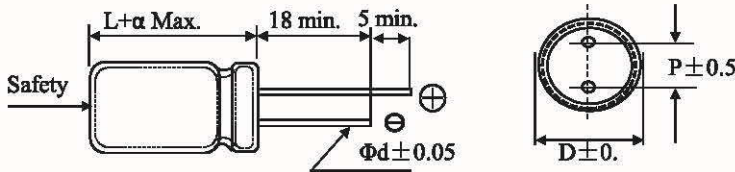

DΦ	5	6.3	8	10	13	16	18	22
F	2.0	2.5	3.5	5.0	5.0	7.5	7.5	10
dΦ	0.5		0.6		0.8			

●PART NUMBER SYSTEM

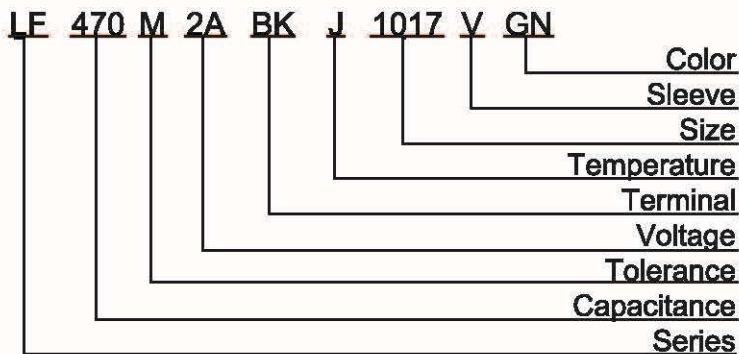

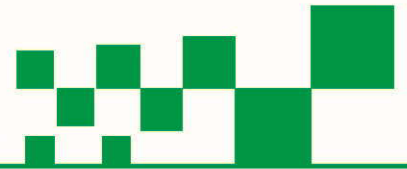

標準額定値 STANDARD RATINGS (Impedance : at20°C 100KHz/Ωmax , Ripple current : mArms/105°C100KHz)

WV (vdc)	Cap (uF)	Case size φD X L(mm)	tanδ	Impedance (Ωmax)	Ripple current (mArms)	
6.3V (0J)	100	5×11	0.20	1.00	170	
	220	5×11	0.20	0.65	310	
	330	6.3×12	0.20	0.42	390	
	470	6.3×12	0.20	0.25	450	
	680	8×12	0.20	0.21	520	
	820	10×13	0.20	0.19	680	
	1000	10×13	0.20	0.17	750	
	1200	10×17	0.20	0.15	950	
	2200	10×20	0.22	0.09	1300	
	3300	13×21	0.24	0.06	1650	
	4700	13×25	0.26	0.036	2100	
	6800	16×25	0.28	0.026	2450	
10V (1A)	100	5×11	0.18	0.80	210	
	220	6.3×12	0.18	0.35	340	
	330	6.3×12	0.18	0.27	460	
	470	8×12	0.18	0.25	580	
	680	10×13	0.18	0.11	765	
	1000	10×17	0.18	0.076	1040	
	1500	10×20	0.18	0.062	1400	
	2200	13×21	0.20	0.041	1755	
	3300	13×25	0.22	0.031	1900	
	4700	16×25	0.24	0.030	2100	
16V (1C)	10	5×11	0.16	4.70	74	
	22	5×11	0.16	2.60	114	
	47	5×11	0.16	1.10	155	
	100	6.3×12	0.16	0.50	265	
	220	6.3×12	0.16	0.25	400	
	330	8×12	0.16	0.156	590	
	470	8×14	0.16	0.124	750	
	680	10×17	0.16	0.092	1100	
	1000	10×20	0.16	0.065	1350	
	1500	13×21	0.16	0.056	1630	
	2200	13×25	0.18	0.035	2000	
	3300	16×25	0.20	0.033	2790	
	4700	16×35	0.22	0.026	2880	
	25V (1E)	10	5×11	0.14	2.56	85
22		5×11	0.14	1.95	125	
33		6.3×12	0.14	1.42	155	
47		6.3×12	0.14	1.1	205	
100		6.3×12	0.14	0.35	320	
220		8×12	0.14	0.15	550	
25V (1E)	330	10×13	0.14	0.114	820	
	470	10×17	0.14	0.076	1200	
	680	10×20	0.14	0.065	1320	
	1000	13×21	0.14	0.045	1650	
	1500	13×21	0.14	0.038	2210	
	2200	13×25	0.16	0.036	2650	
	3300	16×30	0.18	0.026	3240	
	4700	16×35	0.20	0.024	3650	
	35V (1V)	10	5×11	0.12	2.37	105
		22	5×11	0.12	1.5	150
		33	6.3×12	0.12	1.21	180
		47	6.3×12	0.12	0.80	280
		100	8×12	0.12	0.25	450
		220	10×13	0.12	0.114	750
330		10×17	0.12	0.079	1050	
470		10×20	0.12	0.065	1200	
680		13×21	0.12	0.056	1570	
1000		13×25	0.12	0.042	1900	
2200		16×25	0.14	0.034	2850	
3300		18×30	0.16	0.026	3100	
4700		18×40	0.18	0.024	3500	
50V (1H)		0.47	5×11	0.10	5.40	25
	1.0	5×11	0.10	4.00	40	
	2.2	5×11	0.10	2.80	55	
	3.3	5×11	0.10	2.20	60	
	4.7	5×11	0.10	2.00	90	
	10	5×11	0.10	1.82	120	
	22	6.3×12	0.10	1.35	135	
	33	6.3×12	0.10	0.80	250	
	47	8×12	0.10	0.65	280	
	100	10×13	0.10	0.17	480	
	220	10×17	0.10	0.096	930	
	330	10×20	0.10	0.065	1150	
	470	10×20	0.10	0.055	1590	
	680	13×25	0.10	0.044	1930	
1000	13×25	0.10	0.036	2300		
63V (1J)	2200	16×35	0.12	0.032	3040	
	3300	18×35	0.14	0.025	3100	
	10	6.3×12	0.10	1.75	110	
	22	8×12	0.10	0.80	240	
	33	8×12	0.10	0.61	270	

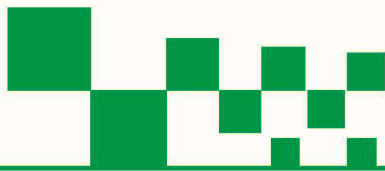

Aluminum Electrolytic Capacitors



標準額定値 STANDARD RATINGS (Impedance : at20°C 100KHz/Ωmax , Ripple current : mArms/105°C100KHz)

WV (vdc)	Cap (μF)	Case size φD X L(mm)	tanδ	Impedance (Ωmax)	Ripple current (mArms)	WV (vdc)	Cap (μF)	Case size φD X L(mm)	tanδ	Impedance (Ωmax)	Ripple current (mArms)
63V (1J)	47	10×13	0.10	0.56	300	250V (2E)	6.8	10×17	0.14	/	140
	100	10×17	0.10	0.14	610		10	10×20	0.14	/	160
	220	10×20	0.10	0.08	1100		22	13×21	0.14	/	185
	330	13×21	0.10	0.055	1250		33	13×25	0.14	/	260
	470	13×25	0.10	0.053	1620		47	16×25	0.14	/	405
	1000	16×35	0.10	0.034	2350		100	16×35	0.14	/	675
100V (2A)	0.47	5×11	0.10	5.90	20	400V (2G)	220	18×40	0.14	/	910
	1.0	5×11	0.10	4.40	30		1.0	8×12	0.15	/	36
	2.2	5×11	0.10	3.30	42		2.2	8×12	0.15	/	65
	3.3	6.3×12	0.10	2.80	55		3.3	8×14	0.15	/	86
	4.7	6.3×12	0.10	2.60	72		4.7	10×14	0.15	/	120
	10	8×12	0.10	1.77	130		5.6	10×14	0.15	/	130
	22	8×12	0.10	0.85	220		6.8	10×17	0.15	/	160
	33	10×13	0.10	0.69	320		10	10×20	0.15	/	245
	47	10×17	0.10	0.58	370		15	13×21	0.15	/	270
	100	10×20	0.10	0.30	560		22	13×25	0.15	/	305
	220	13×25	0.10	0.13	880		33	16×25	0.15	/	335
	330	16×30	0.10	0.10	1440		47	16×30	0.15	/	560
160V (2C)	470	18×30	0.10	0.09	1650	68	16×35	0.15	/	750	
	2.2	6.3×12	0.14	/	55	82	18×30	0.15	/	820	
	3.3	8×12	0.14	/	70	100	18×40	0.15	/	950	
	4.7	8×12	0.14	/	72	450V (2W)	1.0	8×12	0.17	/	41
	10	10×13	0.14	/	91		2.2	10×13	0.17	/	60
	22	10×17	0.14	/	205		3.3	10×17	0.17	/	89
	33	10×20	0.14	/	260		4.7	10×20	0.17	/	130
	47	13×21	0.14	/	320		5.6	10×20	0.17	/	140
	68	13×25	0.14	/	410		6.8	13×21	0.17	/	145
100	16×25	0.14	/	500	10		13×25	0.17	/	165	
220	16×30	0.14	/	820	15		13×25	0.17	/	195	
330	18×35	0.14	/	1000	22		16×25	0.17	/	255	
250V (2E)	1.0	6.3×12	0.14	/	50	33	16×30	0.17	/	360	
	2.2	8×12	0.14	/	72	47	18×30	0.17	/	550	
	3.3	8×12	0.14	/	75	68	18×40	0.17	/	700	
	4.7	10×13	0.14	/	100						